

**FOR INFORMATION ONLY
NOT FOR CONSTRUCTION**

- NOTES:
- This detail is for pedestrian traffic only, not suitable for driveways. For other loadings, pavement design to Engineer's specifications.
 - Comply with all relevant Australian Standards.
 - Refer to relevant Town Centre Streetscape Master Plan and Technical Guidelines for paver selections and performance criteria.
 - Refer to relevant Town Centre Streetscape Master Plan and Technical Guidelines for concrete finishes and performance criteria.

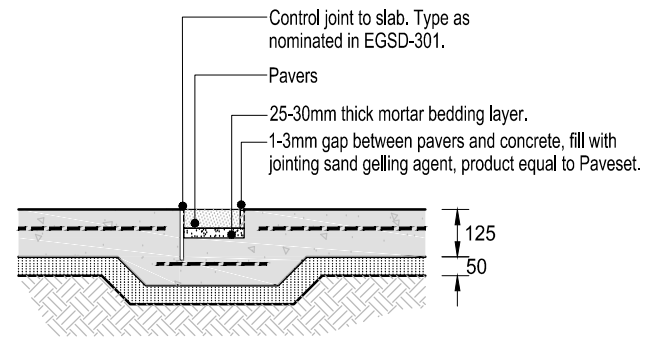
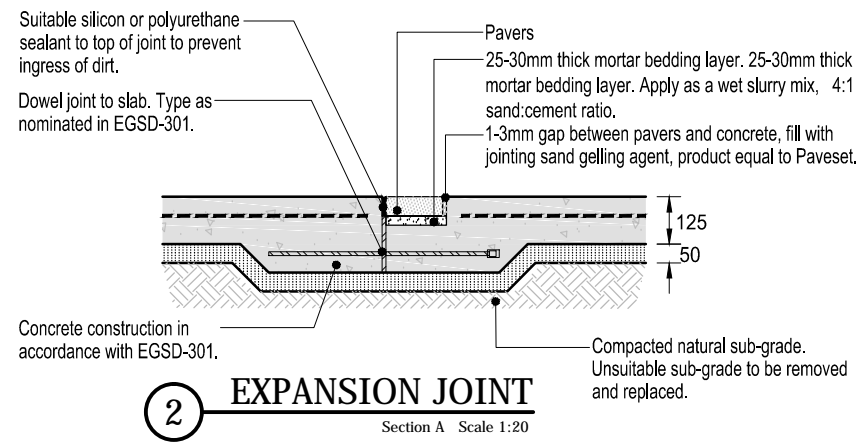
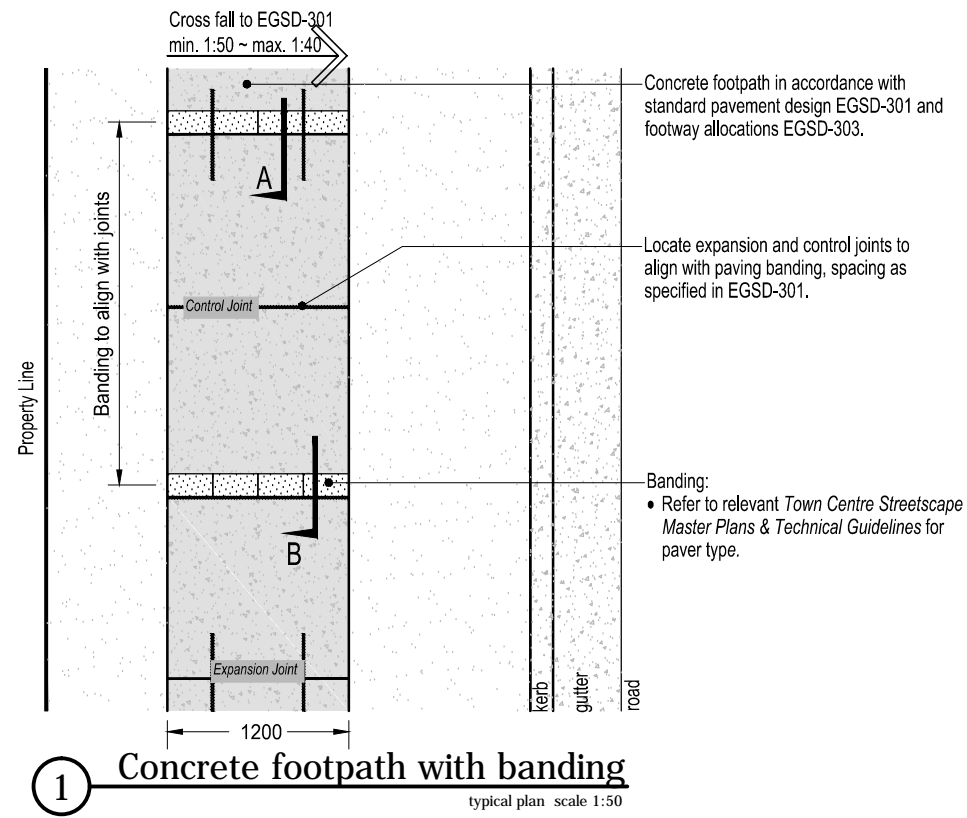

VERSION	DATE	COMMENTS	PAPER SIZE
2	2015-11	Amended format, Review 2015.	A4
1	2013-05	Final for DCP.	A4

WORK TO FIGURED DIMENSIONS – DO NOT SCALE. DO NOT RELY ON THESE STANDARD DRAWINGS AS THE EQUIVALENT OF, OR SUBSTITUTE FOR, PROJECT-SPECIFIC DESIGN & ASSESSMENT BY A QUALIFIED PROFESSIONAL.

126-138 MAIN ROAD
SPEERS POINT
PHONE (02)4921 0333
www.lakemac.com.au
SHEET: 1 OF 1

DRAWING TITLE Standard Drawings - Pavement Concrete footpath - 1.2m wide, with banding	
DRAWING No: LSD-PAV-03	VERSION: 2